

New
GENERATION
**PNEUMATIC
GLUE PUMP**
With integrated heater

For viscous and liquid
media



For Sales and Service

LES INC.
3115 LOCUST ROAD
GILMER, TX 75645
Ph 903.734.5873
Ph 800.391.4867
Fx 903.734.6954



Glue pump, specially developed

- Rapid heating of the glue.
- Integrated heater.
- High operating safety.
- Improved glue transport.
- Easy operation.
- Low noise.

Operating principle:

The Timmer glue pump is a self-priming, air-operated piston dosing pump. The pneumatic piston transfers the force via piston rods to the liquid piston inside the suction pipe. The process is controlled via a reversing valve within the pneumatic part.

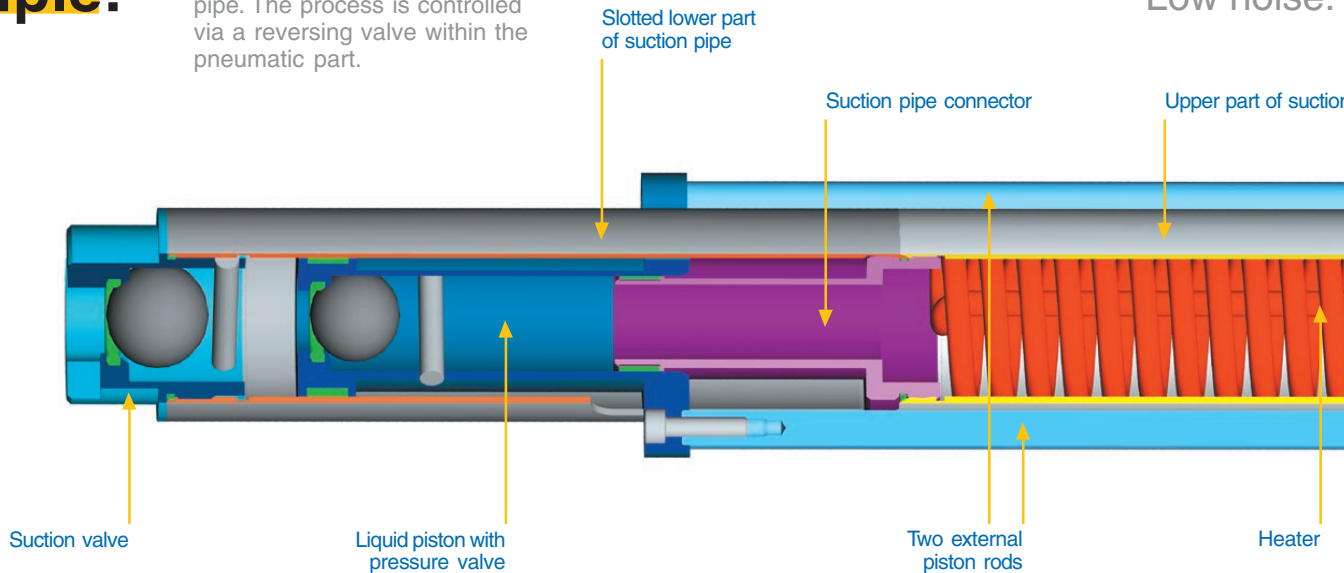

General data

Drive	Pneumatic
Drive principle	Self-priming, volumetric
Driving piston	ø 90 mm
Liquid piston	ø 46 mm
Transmission ratio	3,8:1
Piston stroke	43 mm
Pump capacity (water)	73 cm ³ per double stroke (8 l/min / 480 l/h)
Pump capacity per piston stroke	Upward approx. 50% - downward approx. 50%
Number of strokes per minute	120 strokes/min approx., adjustable via outlet throttle
Viscosity of delivery medium	Up to approx. 100,000 mPas
Pulsation	Low
Suction side - connection	Suction pipe (standard length 420 mm)
Pressure side - connection	Hose socket 19 mm - 3/4" female thread
Suction height	self-priming, approx. 5 m of water column
Overall length	670 mm (other lengths available on request)
Weight	4,5 kg
Made in Germany	

Pneumatic data

Compressed air connection	1/4" female thread
Operating air pressure	3 - 6 bar filtered compressed air
Compressed air consumption	240 l/min max. at continuous operation
Integrated pneumatic valves	Main valve 5/2 directional valve Control valve 3/2 directional valve



for labelling machines.



The glue funnel, the cover and other parts are available as accessories

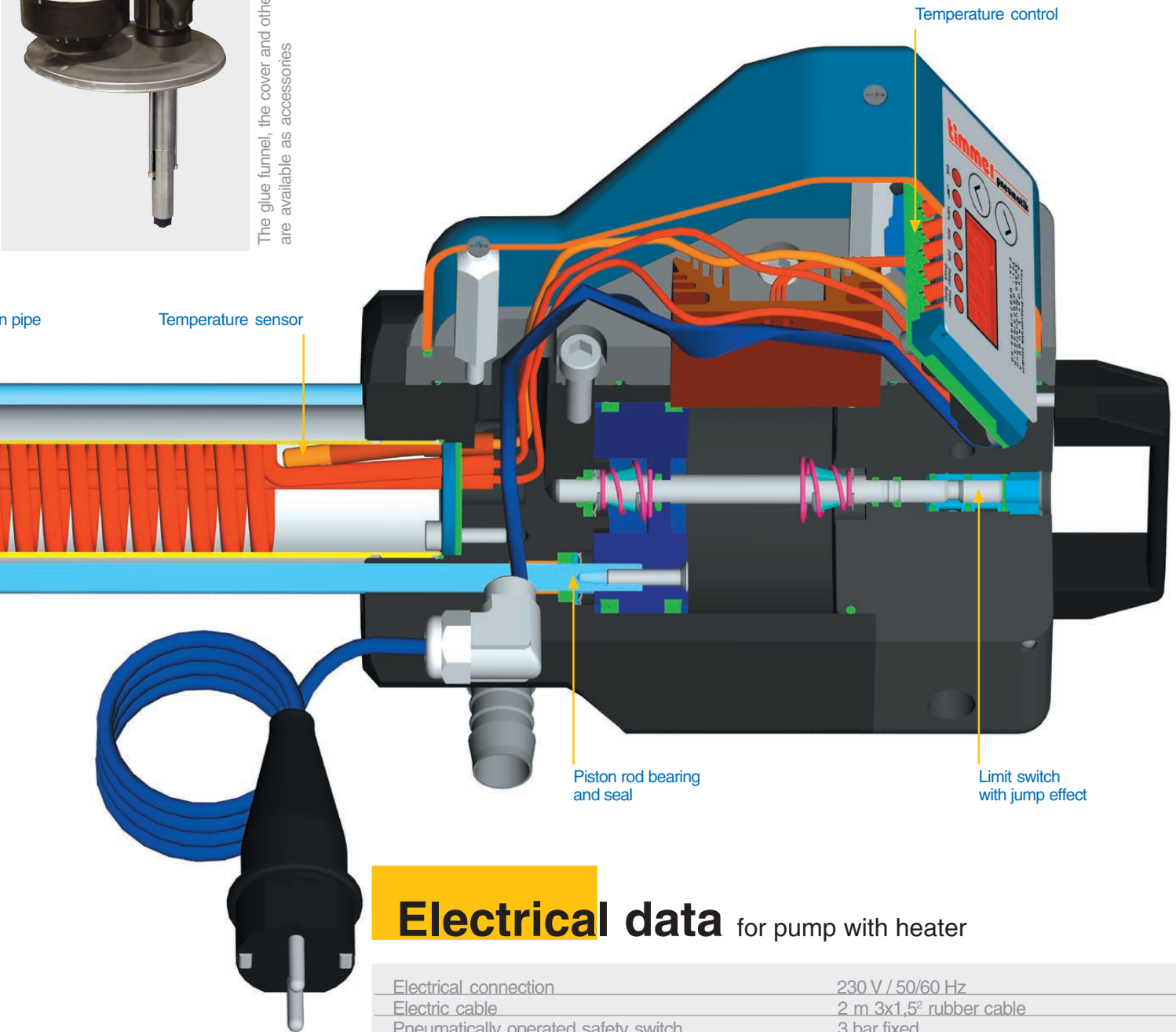

Electrical data for pump with heater

Electrical connection	230 V / 50/60 Hz
Electric cable	2 m 3x1,5 ² rubber cable
Pneumatically operated safety switch	3 bar fixed
The desired temperature is programmable and is reached via the four power levels 1-4.	1400 Watt level 1 = 100% heating output 700 Watt level 2 = 50% heating output 350 Watt level 3 = 25% heating output 175 Watt level 4 = 12,5% heating output
Temperature controller	Electronic two-step controller
Temperature setting	Vis display and keyboard membrane
Temperature range	Programmable up to +90° C
Glue temperature inlet - outlet	ΔT approx. 7° C
Stainless steel temperature sensor	Electronic
Thermal overload protection	+90° C

Material data

Drive housing	POM - polyacetal
Liquid housing	POM - polyacetal
Suction pipe	Stainless steel 1.4301
Liquid seal	PTFE seal ring (Teflon)
Liquid valve balls	Stainless steel 1.4301
External piston rods	Stainless steel 1.4301, polished
Electrical housing	PE - polyethylene
Outlet	POM - 19 mm hose nozzle
Suction base	POM - polyacetal
Liquid valve seat	Viton - O-ring

**Air-operated piston pump with integrated heater**

programmable up to +90° C
 consisting of:
 pump with pneumatic drive
 electronic control
 integrated heater
 temperature sensor
 pneumatic-electric pressure switch
 electric cable 3x1,5² - 2 m



Best.-Nr.: 5400 - 2000
 Typ: PD02-H102

**Air-operated piston pump without heater**

consisting of:
 pump with pneumatic drive



Best.-Nr.: 5400 - 1000
 Typ: PD02-O102

**Glue cover, complete**

consisting of:
 glue cover - stainless steel
 plastic funnel with bayonet fastener
 stainless steel sieve



Best.-Nr.: 5901 - 0009
 Typ: PD02-ZUB-Leimdeckel-kpl.-VA-01

**Mounting clamp ring (pump height adjustment)**

consisting of:
 plastic clamp ring
 clamping screw



Best.-Nr.: 5500 - 1000
 Typ: PD02-ZUB-Montageklemmring

**Compressed-air connection with 2 m or 5 m hose**

consisting of:
 1 x filter/controller 1/4"
 1 x miniature ball valve 1/4"
 1 x compressed air hose 2 m or 5 m
 outside ø: 12 mm / inside ø: 6 mm
 1 x nozzle for coupling NW 7



2m Best.-Nr.: 5202 - 0074
 Typ: PD02-ZUB-DLA105

 5m: Best.-Nr.: 5202 - 0065
 Typ: PD02-ZUB-DLA110

**Feed hose PVC 2 m or 5 m**

consisting of:
 1 x PVC hose 27/19 - 2 m or 5 m
 1 x hose clamp



2m: Best.-Nr.: 5202 - 0073
 Typ: PD02-ZUB-FS202

 5m: Best.-Nr.: 5202 - 0068
 Typ: PD02-ZUB-FS201

**Electrical connection - grounding type plug**

consisting of:
 1 x grounding type plug, ready assembled



Best.-Nr.: 5202 - 0069
 Typ: PD02-ZUB-SCHUCO

**Electrical connection - Euro plug (shaped plug)**

consisting of:
 1 x plug CEE 3x16 A 220V
 with cable kink protection, ready assembled



Best.-Nr.: 5202 - 0071
 Typ: PD02-ZUB-CEE-Formstecker-3x16A-220V

**Procon - plug**

consisting of:
 1 x Procon plug, ready assembled



Best.-Nr.: 5202 - 0070
 Typ: PD02-ZUB-PROCON

It is absolutely necessary to read the handling instructions carefully before the pump is used!
 © Timmer Pneumatik GmbH 2001